

P1000

Rail de montage

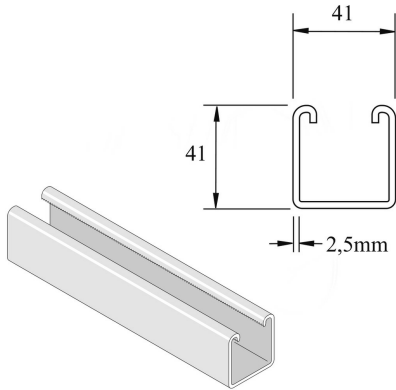

Exec. Std.

Sendzimir

HD	Référence	↕ mm	↔ mm	→ ← mm	↔ mm	kg/m	📦	Magasin	Unité
-	P1000P	41	41	2,5	6000	2,748	6	X	M
-	P1000	41	41	2,5	6000	2,792	6	X	M
-	P1000DF	41	41	2,5	6000	2,880	6	X	M
-	P1000PX3	41	41	2,5	3000	2,748	3		M
-	P1000X3	41	41	2,5	3000	2,880	3	X	M
-	P1000HX3000	41	41	2,5	3000	2,880	3		M

Abbréviation:

- PO = Non Traité
- ZP = Galvanisé
- HG = Galvanisé à Chaud
- DF = Defender