

I6KLLI60

Cable ladder interlocking ends

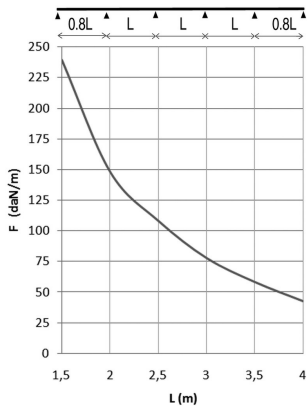
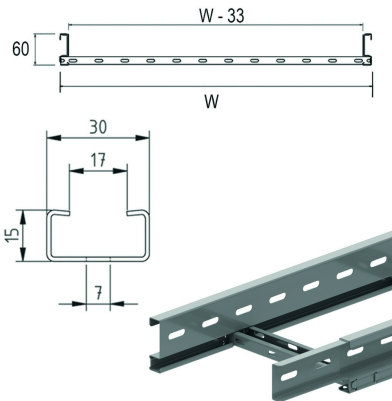

Side walls: perforated S-profile
Perforated C rungs 15 x 30

Standard finish

Stainless Steel 316

HD	Reference	↑ mm	↔ mm	→ ← mm	↔ mm	kg/m	📦	Stock	Unit
-	I6KLLI60.150	60	150	1	3000	2,110	30		M
-	I6KLLI60.200	60	200	1	3000	2,067	30		M
-	I6KLLI60.300	60	300	1	3000	2,400	30		M
-	I6KLLI60.400	60	400	1	3000	2,590	30		M
-	I6KLLI60.500	60	500	1	3000	2,790	30		M
-	I6KLLI60.600	60	600	1	3000	3,224	30		M

LOAD DIAGRAM

This diagram illustrates the permissible uniformly distributed horizontal loads applied to multiple supports. They comply with IEC 61537 with connection in the centre of the span and the end span = 0,8x the span.

F = max. admissible load (daN/m)

L = support distance (m)

Max. deflection (m) = L/100

CHARACTERISTICS

- lightweight
- strong
- interlocking
- partition (I6SLOS35) can be fixed to the cable ladder with a sliding nut (I6GM6) and pan head bolt (I6RB6.10)
- no further coupling holes are required if the cable ladder is cut
- use joiners (I6KLLKP60) and bolts (I6VM6.10) to join the cut lengths of cable ladder
- no joiners are required to attach accessories such as bends, tees etc.
- rungs are perforated to enable efficient attachment of cables.

TECHNICAL INFORMATION

Side walls are constructed from S profile with a return flange and are continuously perforated

Side walls are continuously perforated

C-profile rungs are fixed at 250 mm intervals

Rungs are mechanically attached to the side wall of the cable ladder
Rungs are alternately placed with openings upwards and downwards.

Pickled and passivated.

Fix with:

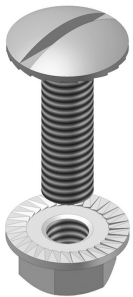

Toothed round head bolt / flange nut
I6VM