

P1037

Winkelhalterung 90° 90x51 3D14

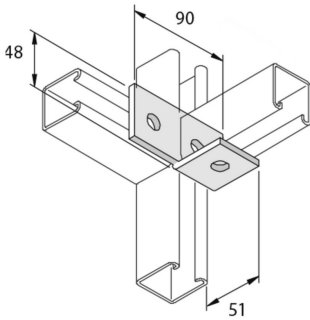

| Standardausführung | | Tauchfeuerverzinkt | | | | | | | |
|--------------------|--------------|--------------------|---------|------------|---------|--------|----|-------|---------|
| HD | Referenz | ↕ mm | ↔ mm | → ← mm | ↔ mm | kg/stk | 📦 | Lager | Einheit |
| - | P1037 | 51 | 48 | | 90 | 0,317 | 10 | | STK |

Abkürzung:
 - HG = Tauchfeuerverzinkt